

OUTLET PERFORMANCE CERTIFICATE

ID: Galvin Engineering 285034 – DI Hi-Flow HD Flat Grate Outlet 150BSP

Test Results	ID: 285034
---------------------	-------------------

Description	DI Hi-Flow Heavy Duty Flat Vert Rainwater Outlet (No Mem/ring) 150BSP
Drain Type	Ø150mm Heavy Duty Flat Grate
Model	285034
Outlet Size	Ø150mm
Test Date	14/07/2017

Grate Drawing

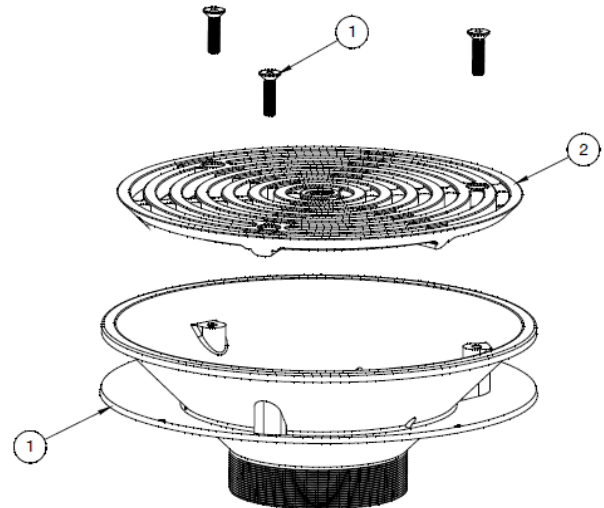
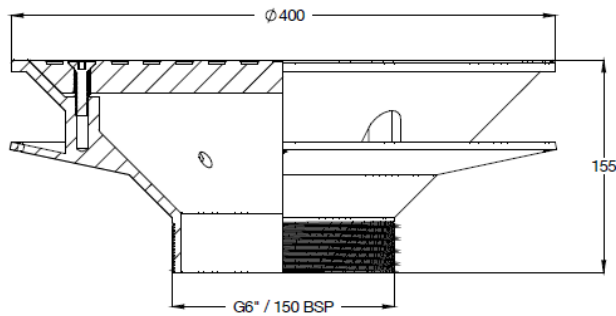

Downpipe Configuration Tests	Standard pipe configurations as shown in Figures 3-6 of AHSCA Research Foundation - Flow Capacity and Water Level Test Protocol for Roof and Balcony Drainage Outlets
-------------------------------------	---

Flow Characteristic Curve – 285034 – DI Hi-Flow HD Flat Grate Outlet 150BSP

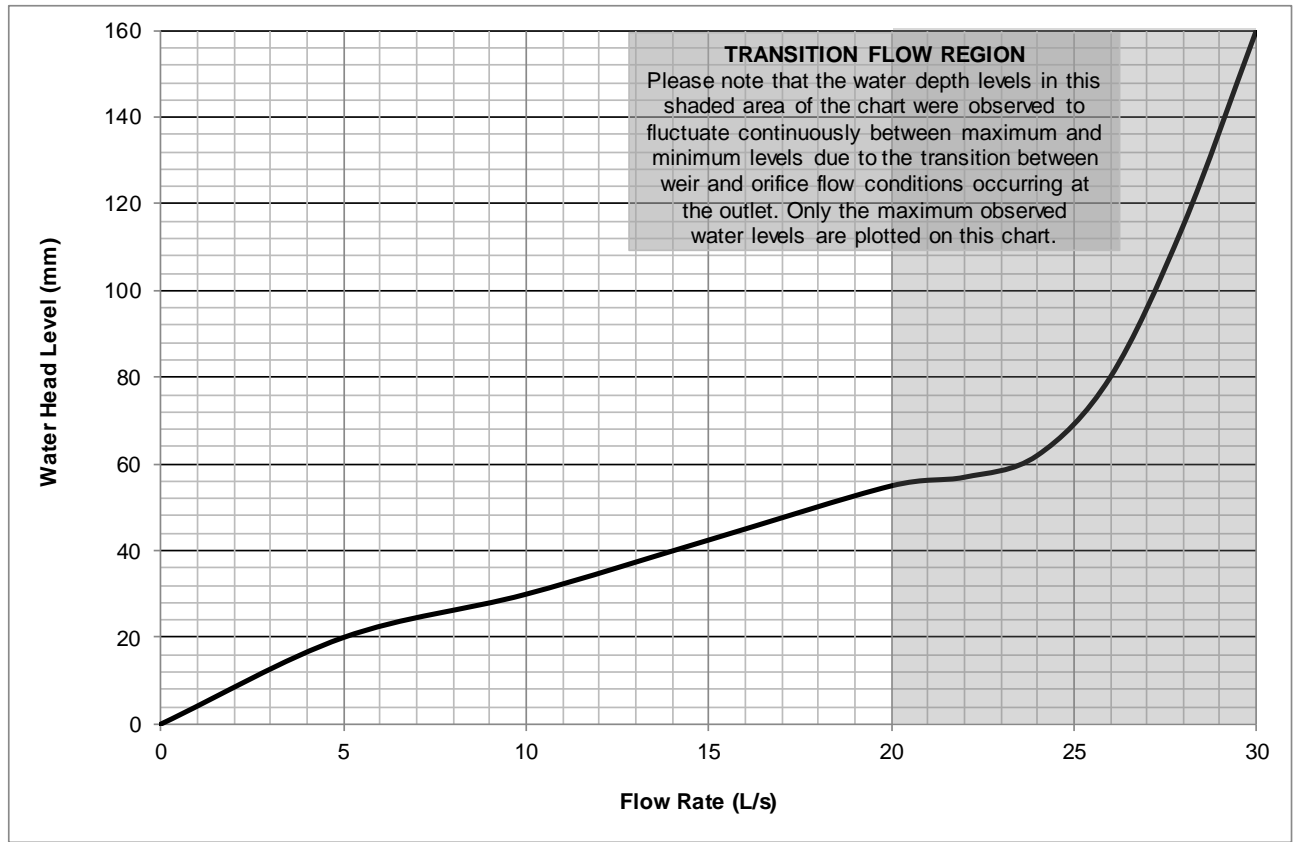

5.0 L/s (20 mm)



18 L/s (50 mm)

Observation Comments:

- Flow curves for all outlet configurations were similar up until approximately 20L/s.
- Transition flows occurred at flowrates above 20L/s. However, the maximum observed flow depth is recorded in the outlet performance curve.

I hereby certify that the test results presented on this outlet performance certificate are true and correct and were obtained using recognised AHSCA Gutter Outlet Testing procedures.

Dr Terry Lucke,
Chief Researcher:



Mark Alexander,
AHSCA Foundation Chairman:



Date: 27th July 2017

Date: 27th July 2017